

# PESTATAK



The **Eazy Slider** is designed primarily for the commercial application, with ease of operation, cleaning and access to existing windows. It is also suitable for domestic use. Two, three, four or more sliding panes can be housed in a continuous run, with maximum recommended height of 2.1m\*.

**Construction** - All inner frame corners are mitred and screwed, giving excellent rigidity to frames. Fixing is through the strong outer framing, with cover caps for screw entry holes into window reveals.

**Application** - This allows the sliding units to be fitted away from protruding handles that would otherwise obstruct fixed frame systems. These sliding screens do not interfere with existing window decor or intrude into room space.

Sliding patio doors or double hinged doorways can be effectively screened.

**Mesh** - Standard fibreglass or aluminium 18x16 insect screening is housed in the sliding frame.

**Colour** - Standard colour is white framework With charcoal mesh.

**Options** - Alternative products from the mesh range can also be used giving both insect and sun protection.

Ask for details and advice to suit your premises and requirements.

\*It is advised that a mid bar be used on larger panels over 1.5m.

Not available in kits.

To buy custom made  
Sliding screens  
please visit our web shop  
[pestatak.co.uk](http://pestatak.co.uk)  
see window screens  
Items 1SA091/2

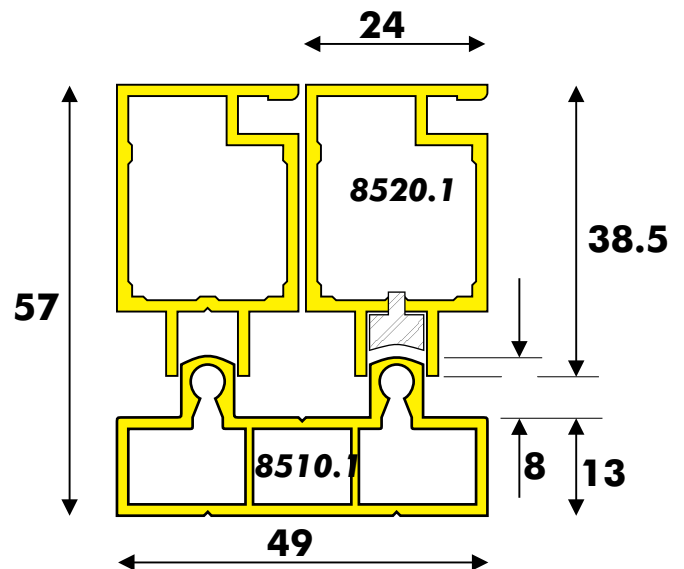
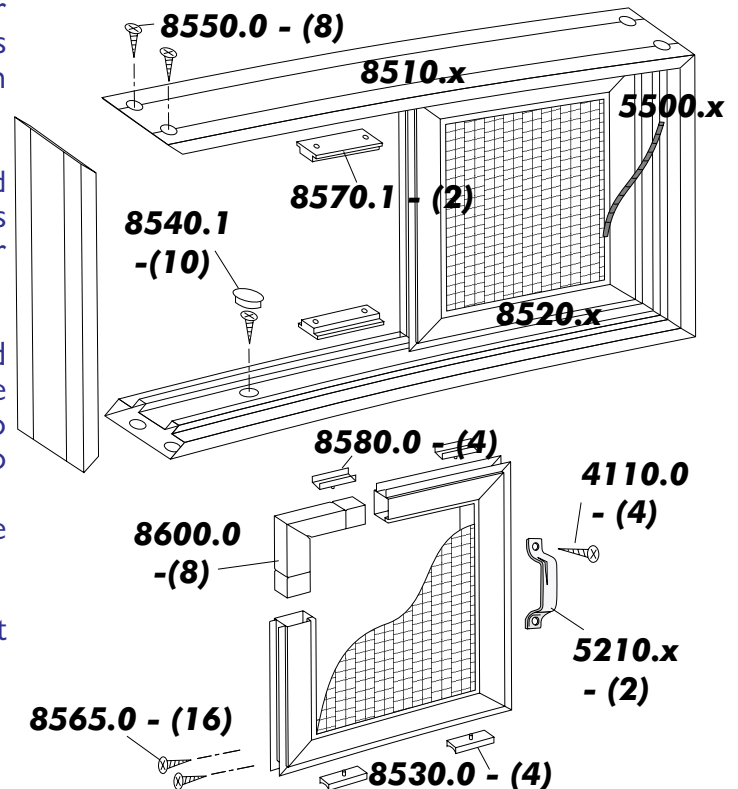

**Above: Slider Inner and Outer Profile shown to scale**

## **Eazy Horizontal Sliding Screen**